

# IRDA

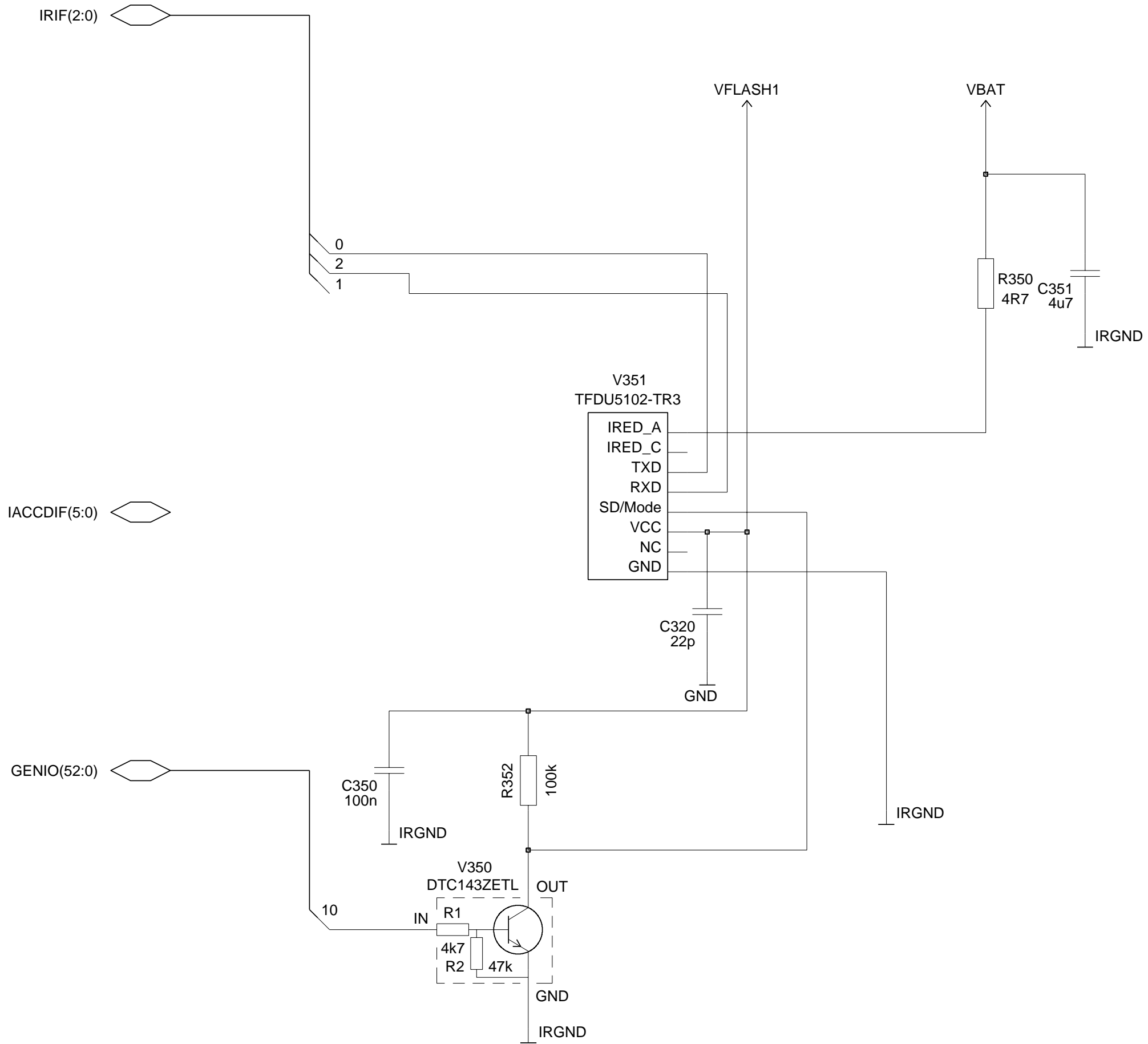

# JTAG

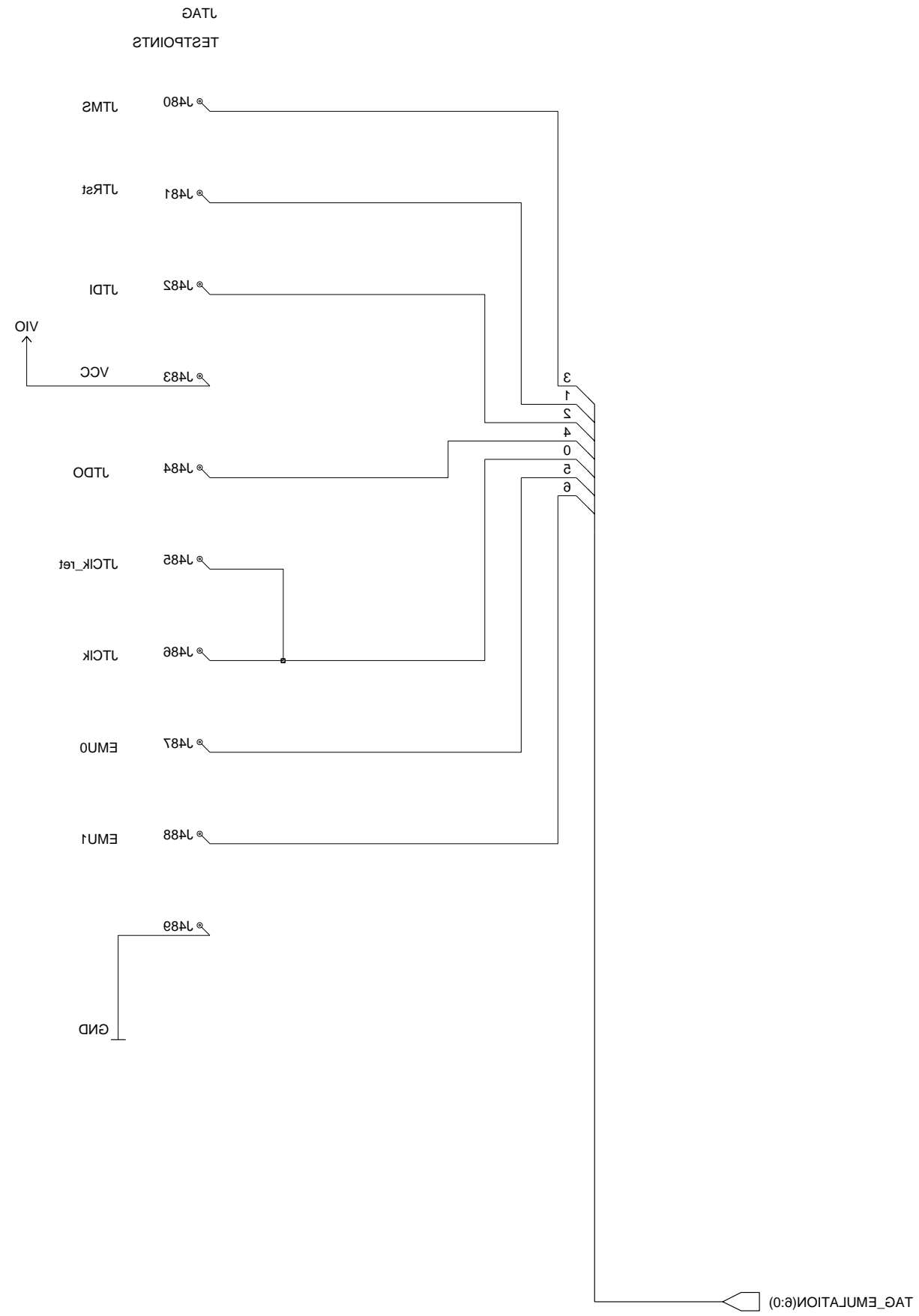

# Keyboard Interface

- PUSL(3:0)
- MIC(2:0)
- DIFDATA(7:0)
- DIFCTRL(3:0)

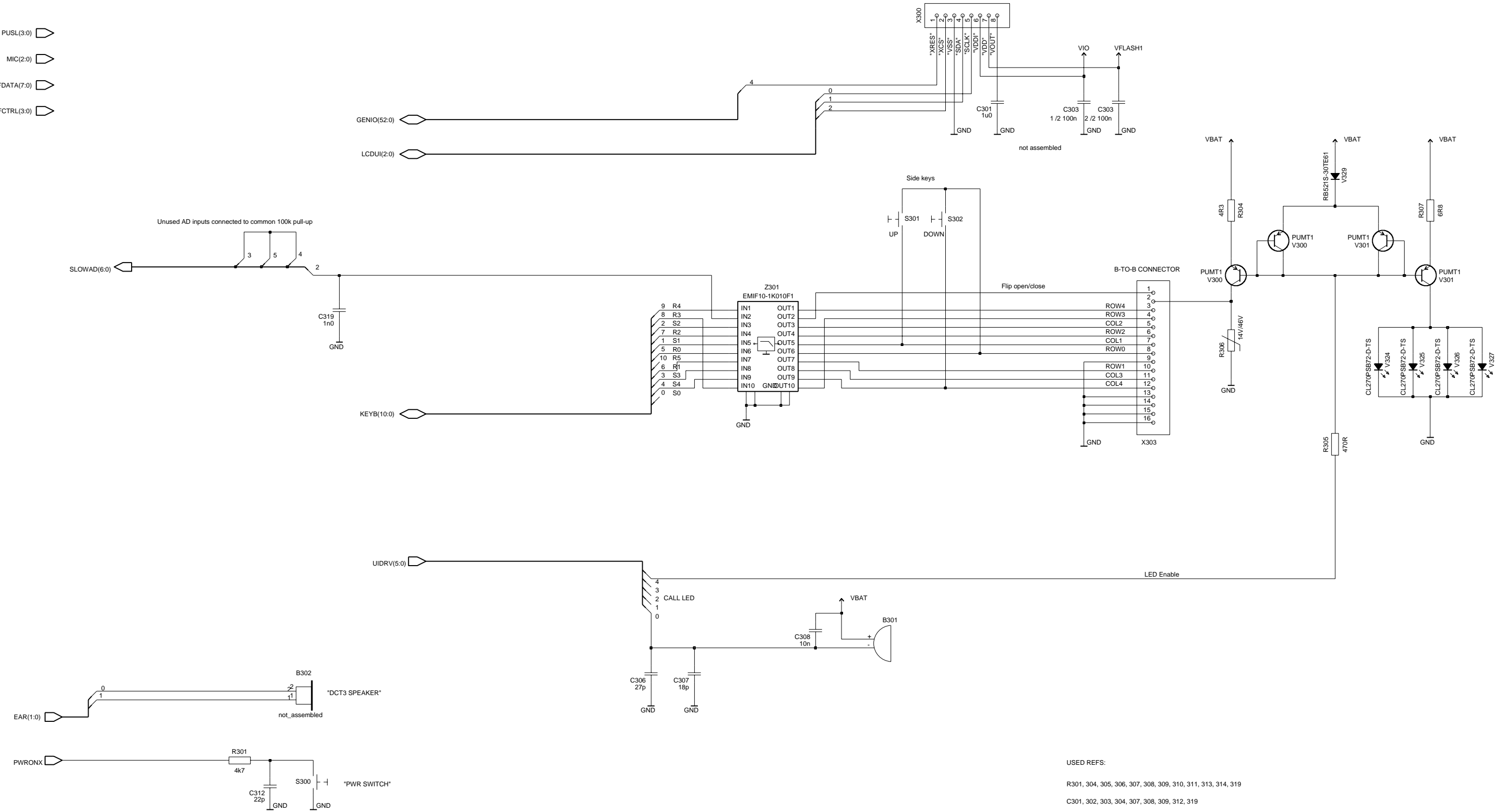

# Memory Filter

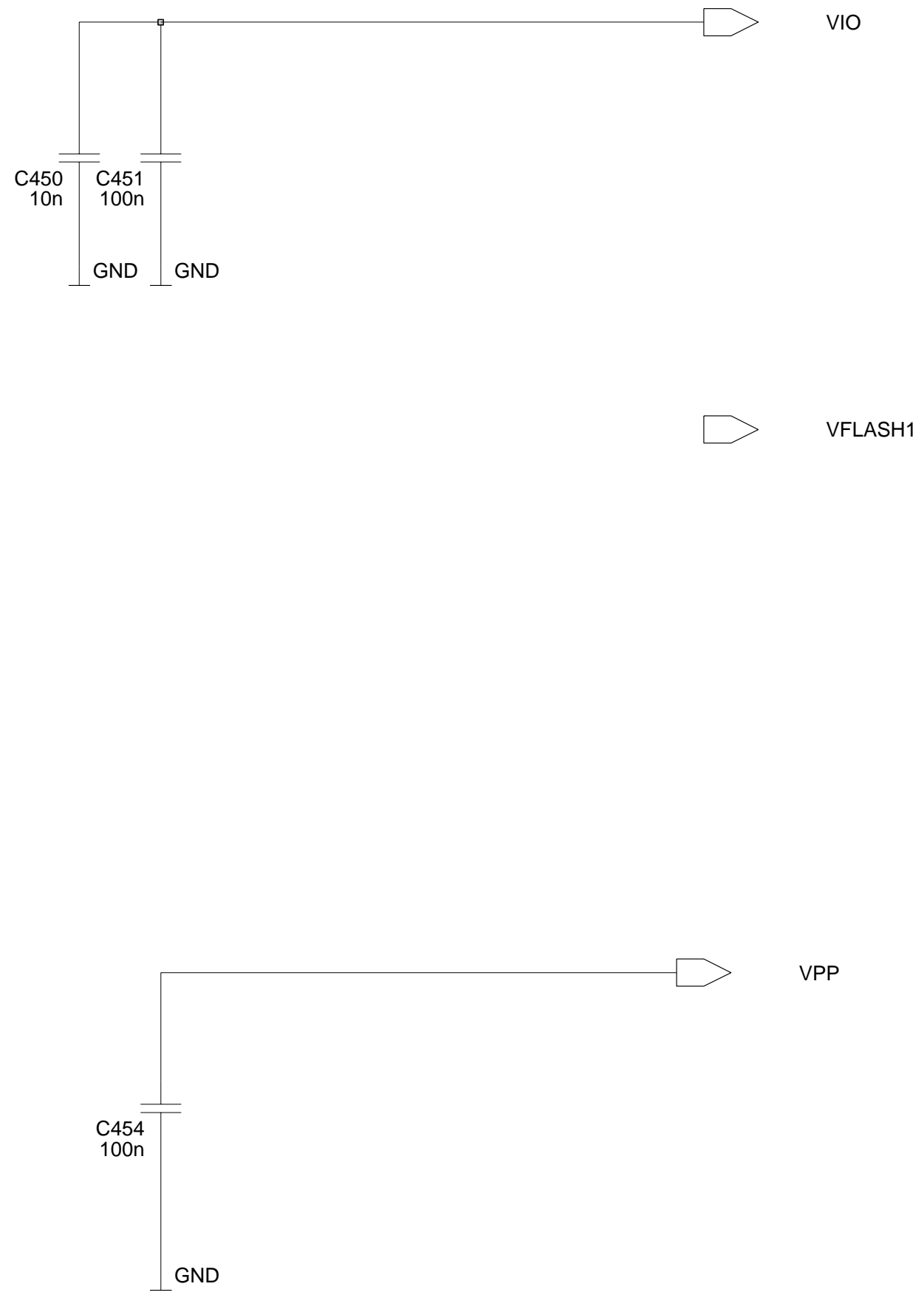

# Flash Memory

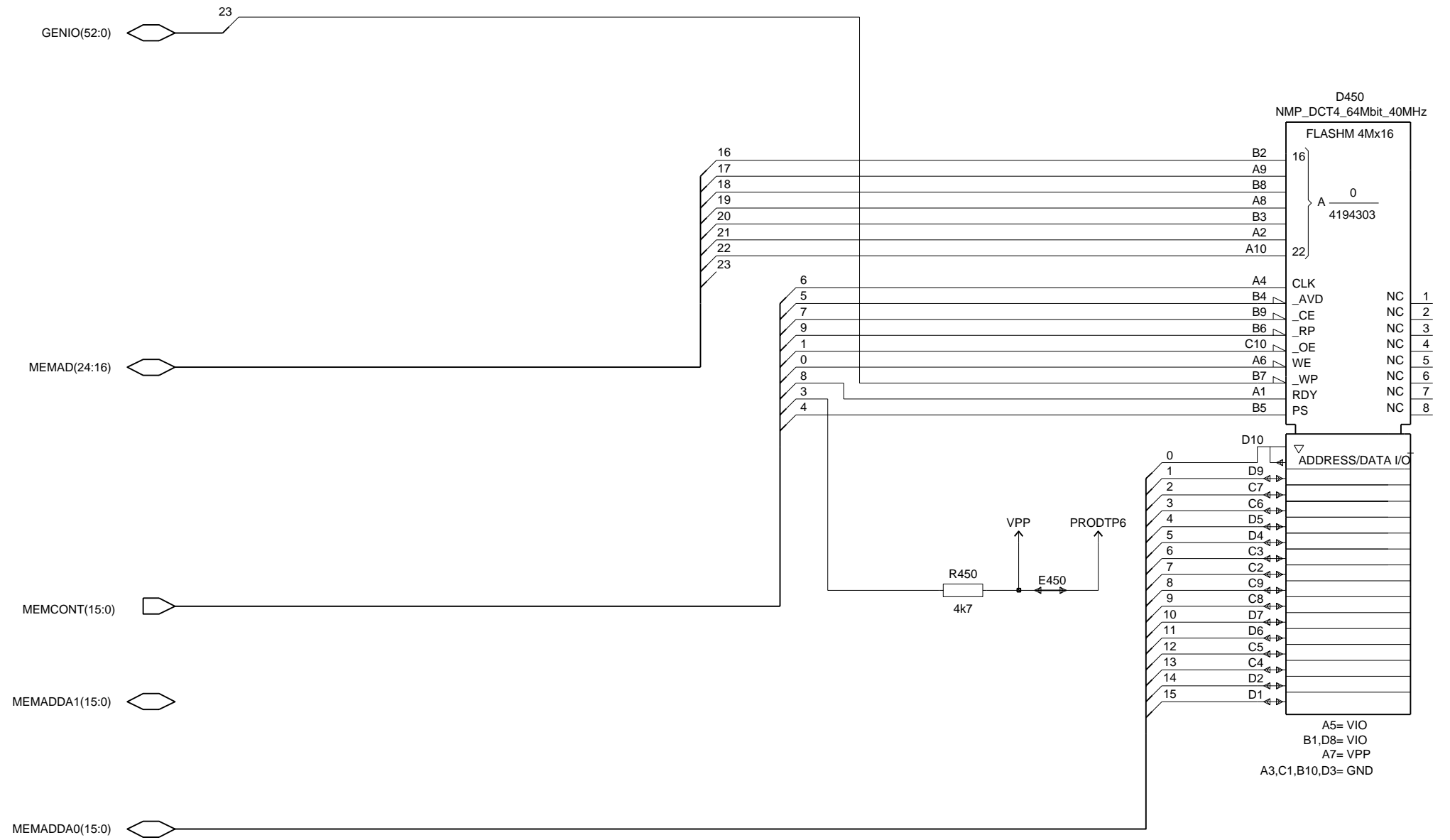
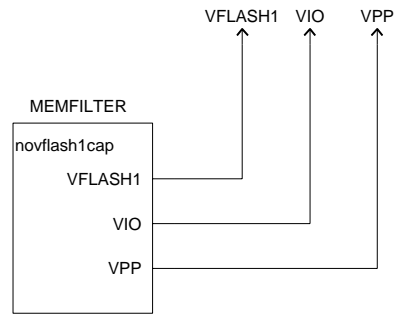

# Ostrich

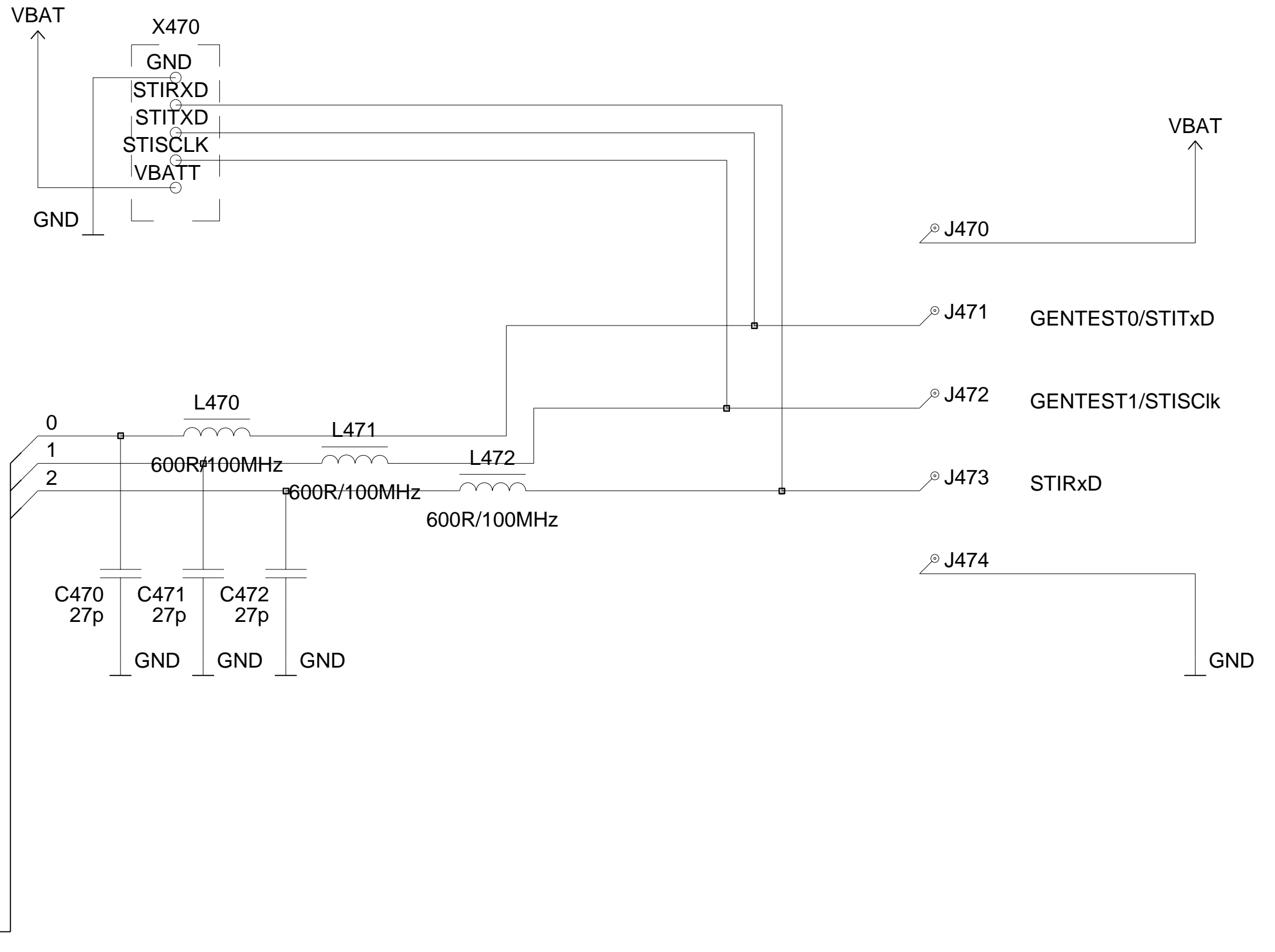

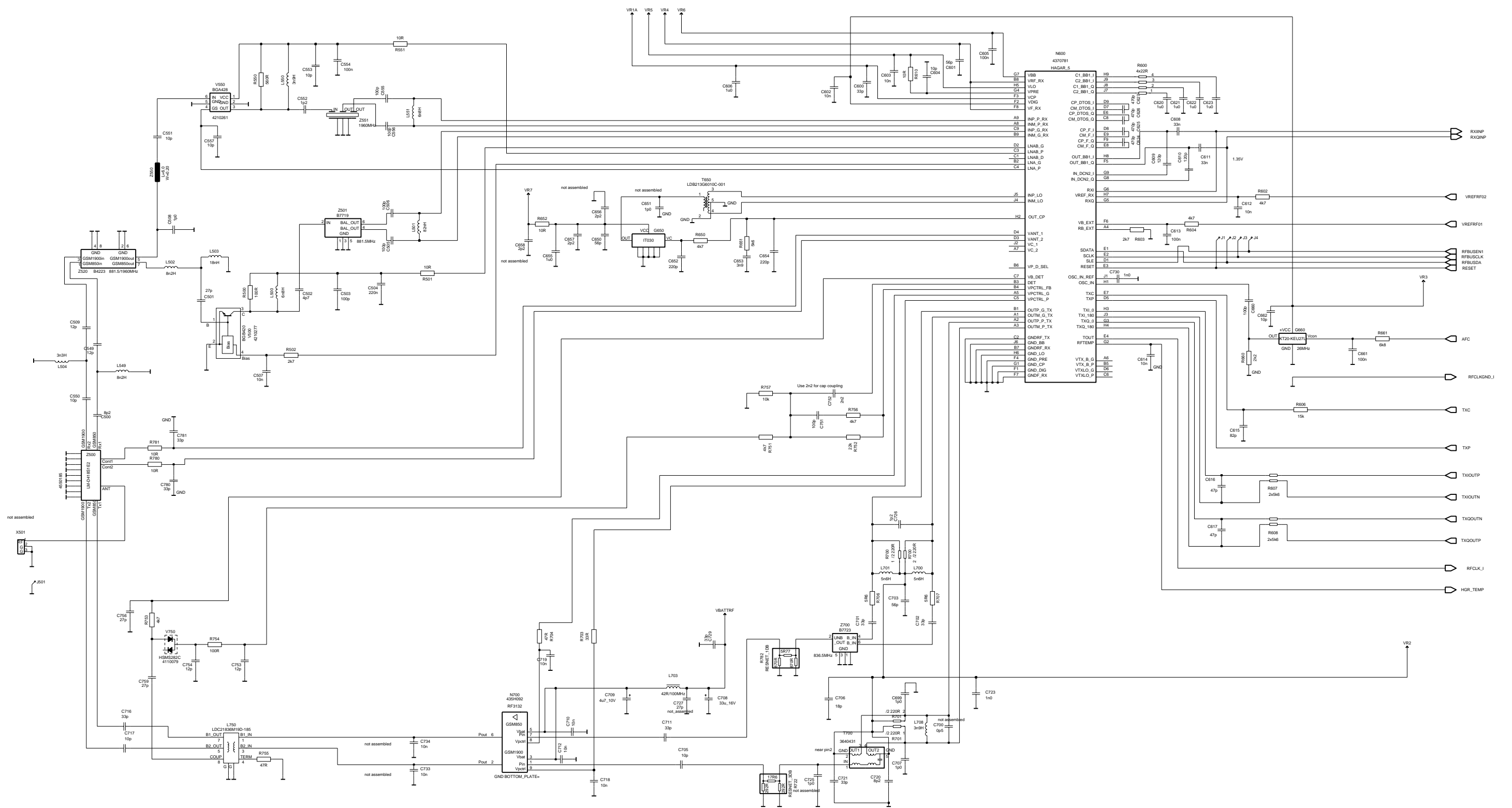

RF & BB

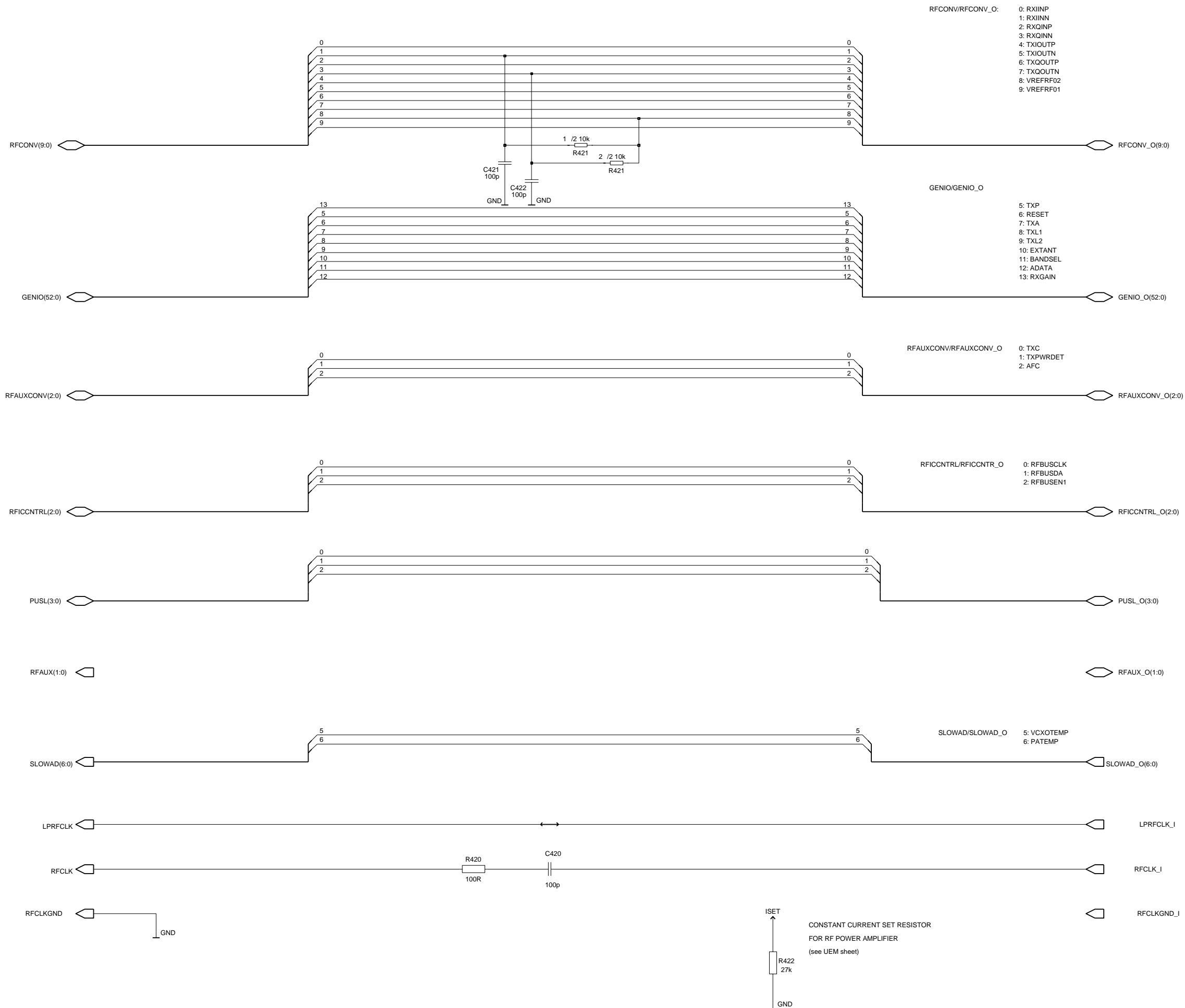



# SIM Reader

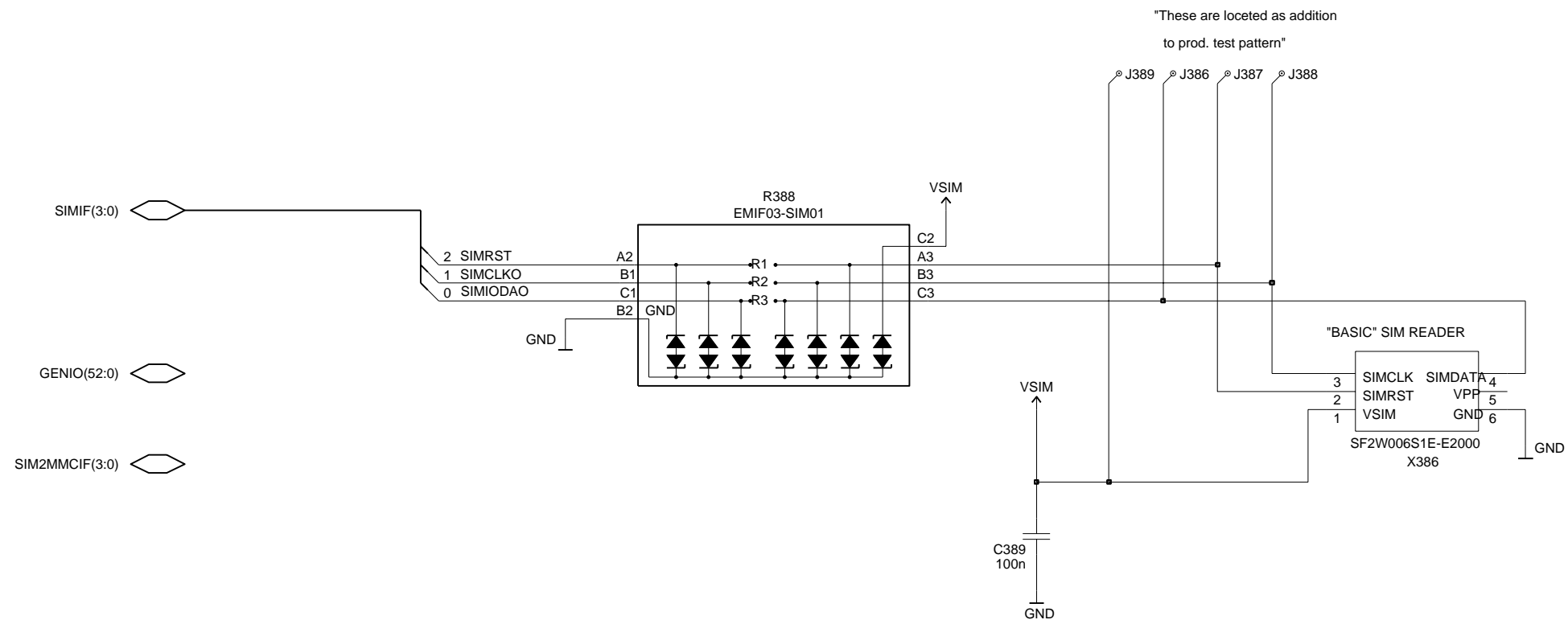

# System Diagram

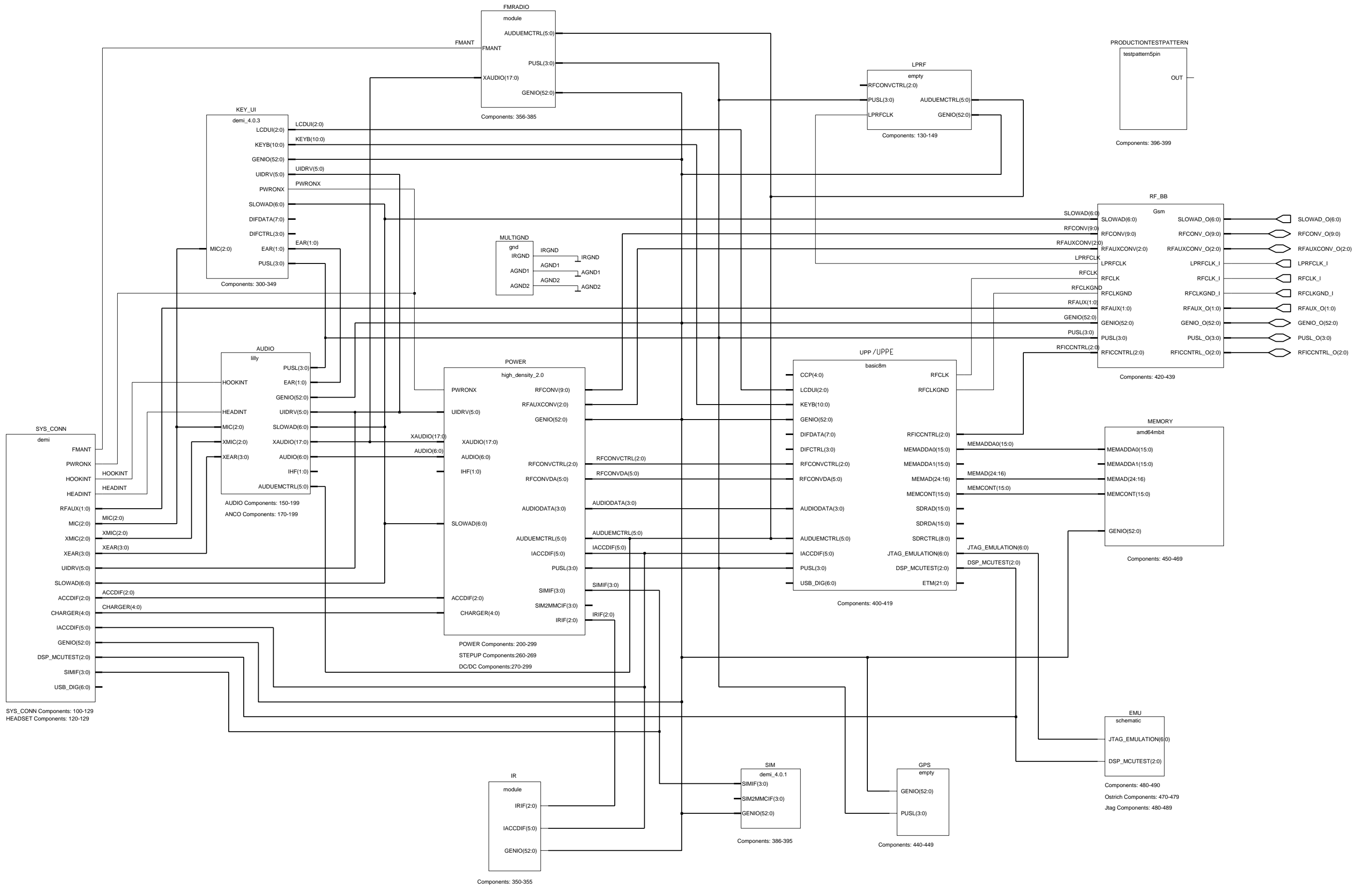

# System Connectors

Varistor arrays have reliability issues

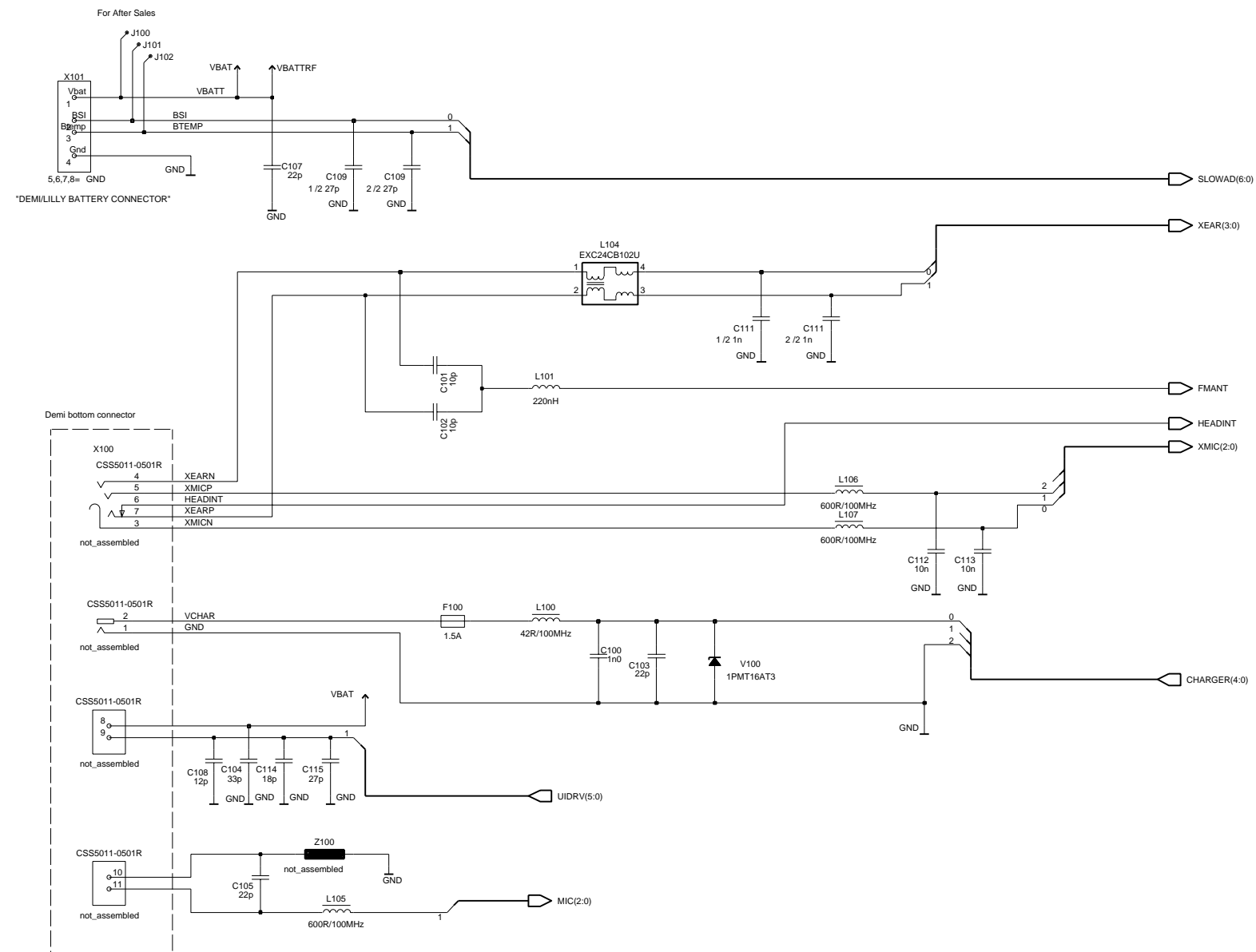

- DSP\_MCU TEST(2:0)
- USB\_DIG(6:0)
- GENIO(5:2:0)
- IACCDIF(5:0)
- RFAUX(1:0)
- PWRONX
- SIMIF(3:0)
- HOOKINT

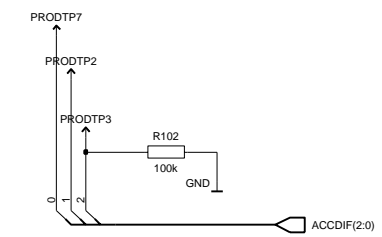

USED REFS:

- R103,
- C100, 101, 102, 103, 104, 106, 108, 109
- L101, 101, 102, 103, 104

Production Test Patterns

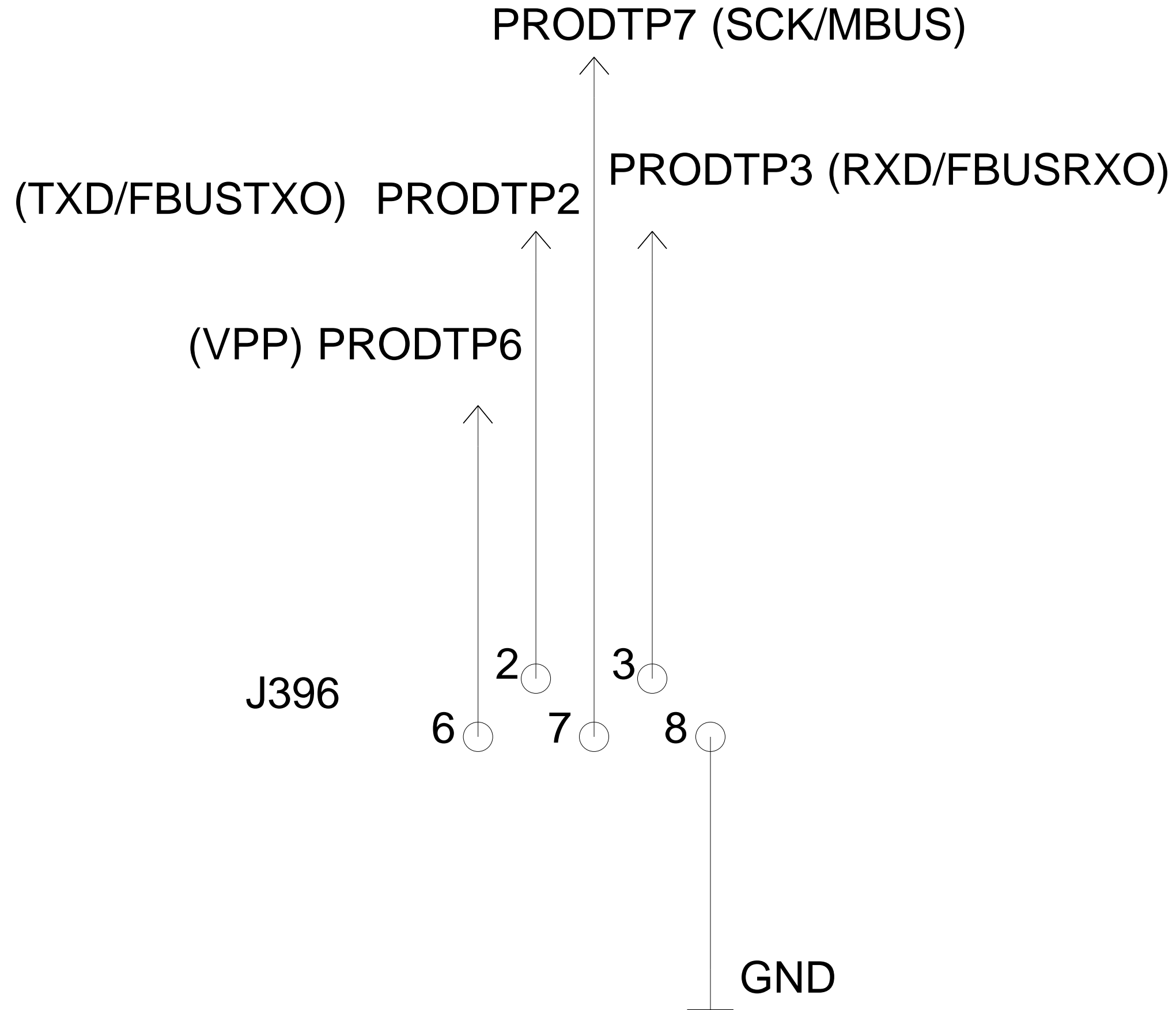

UEM

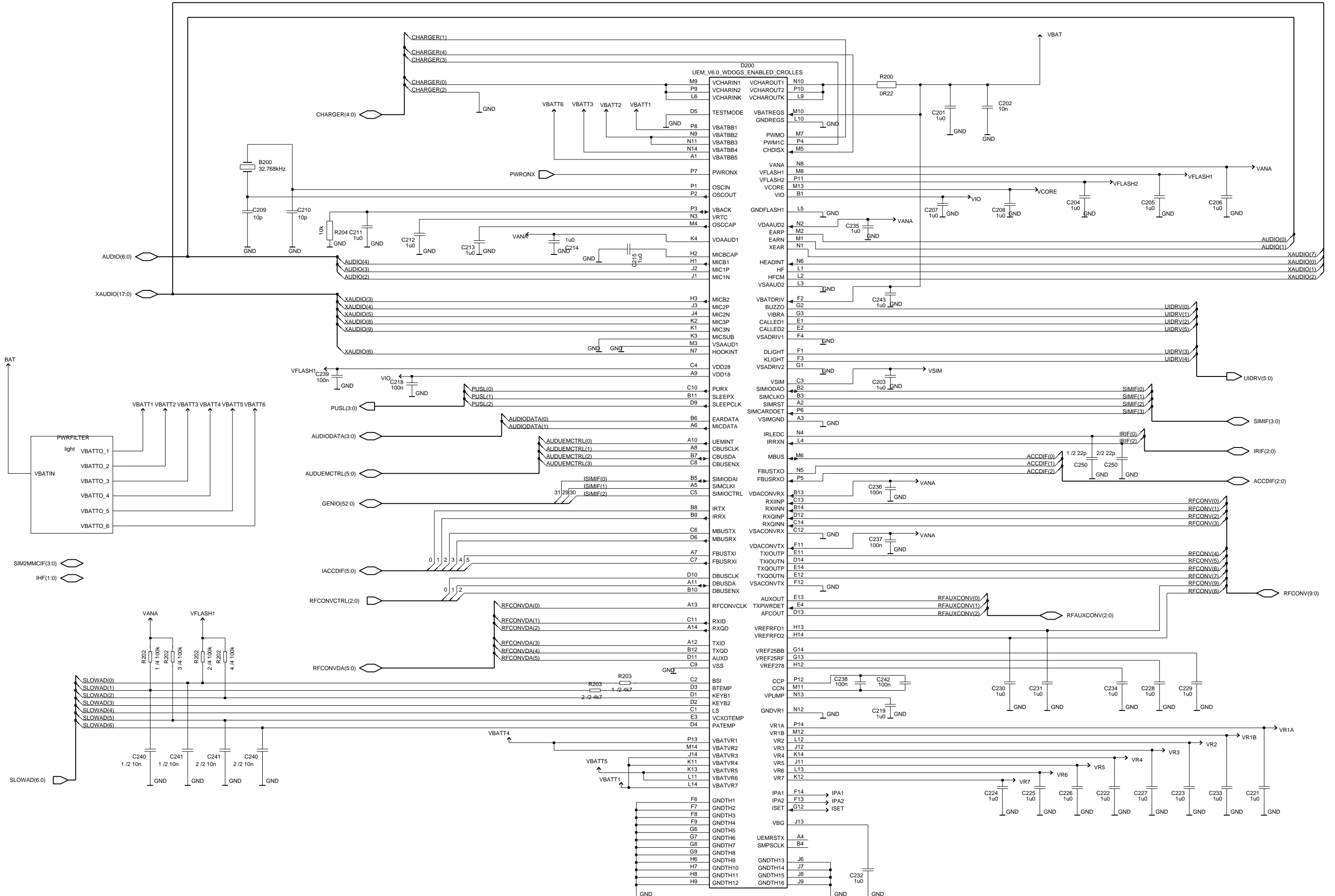

# UEM Filter

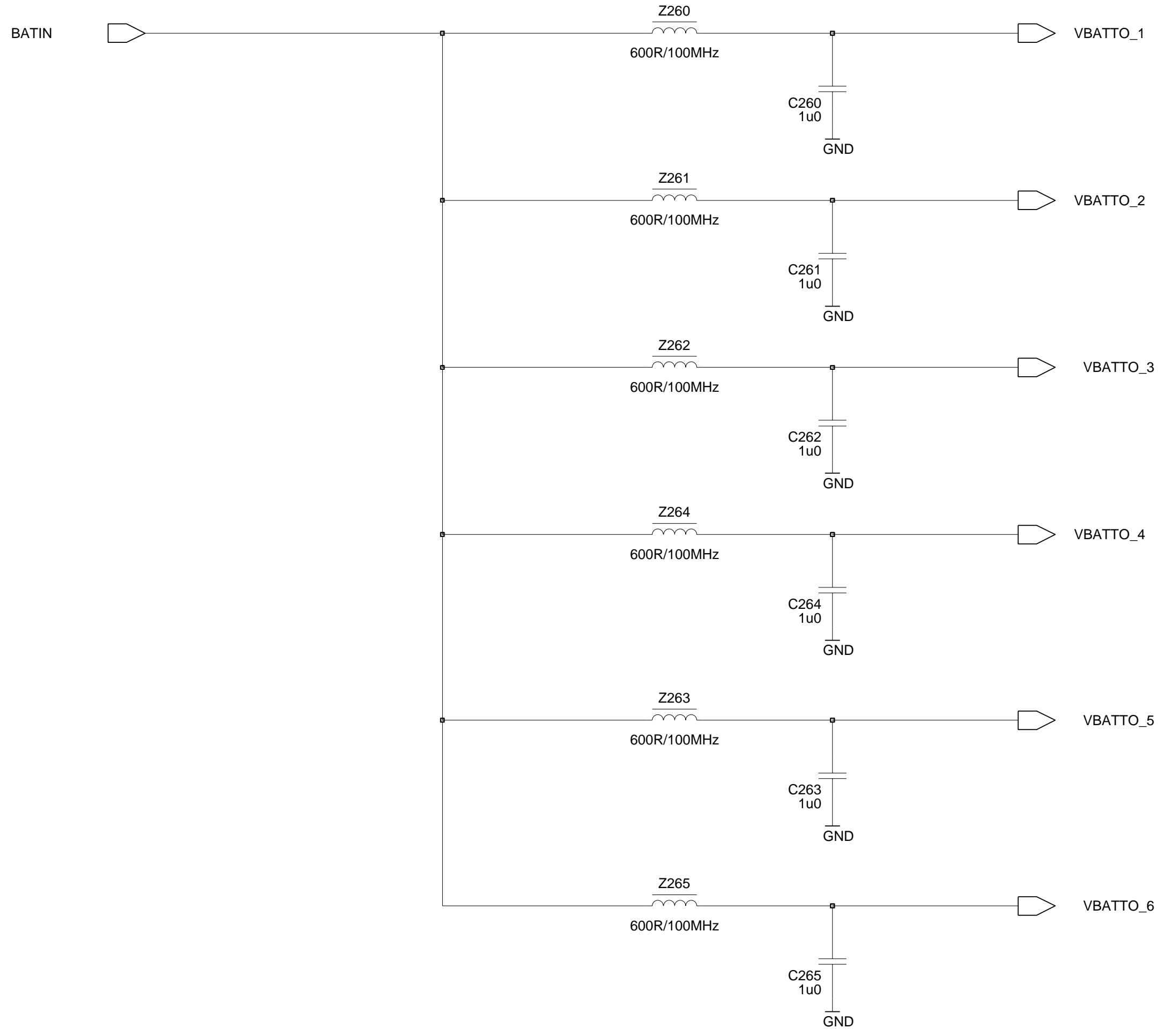

UPP

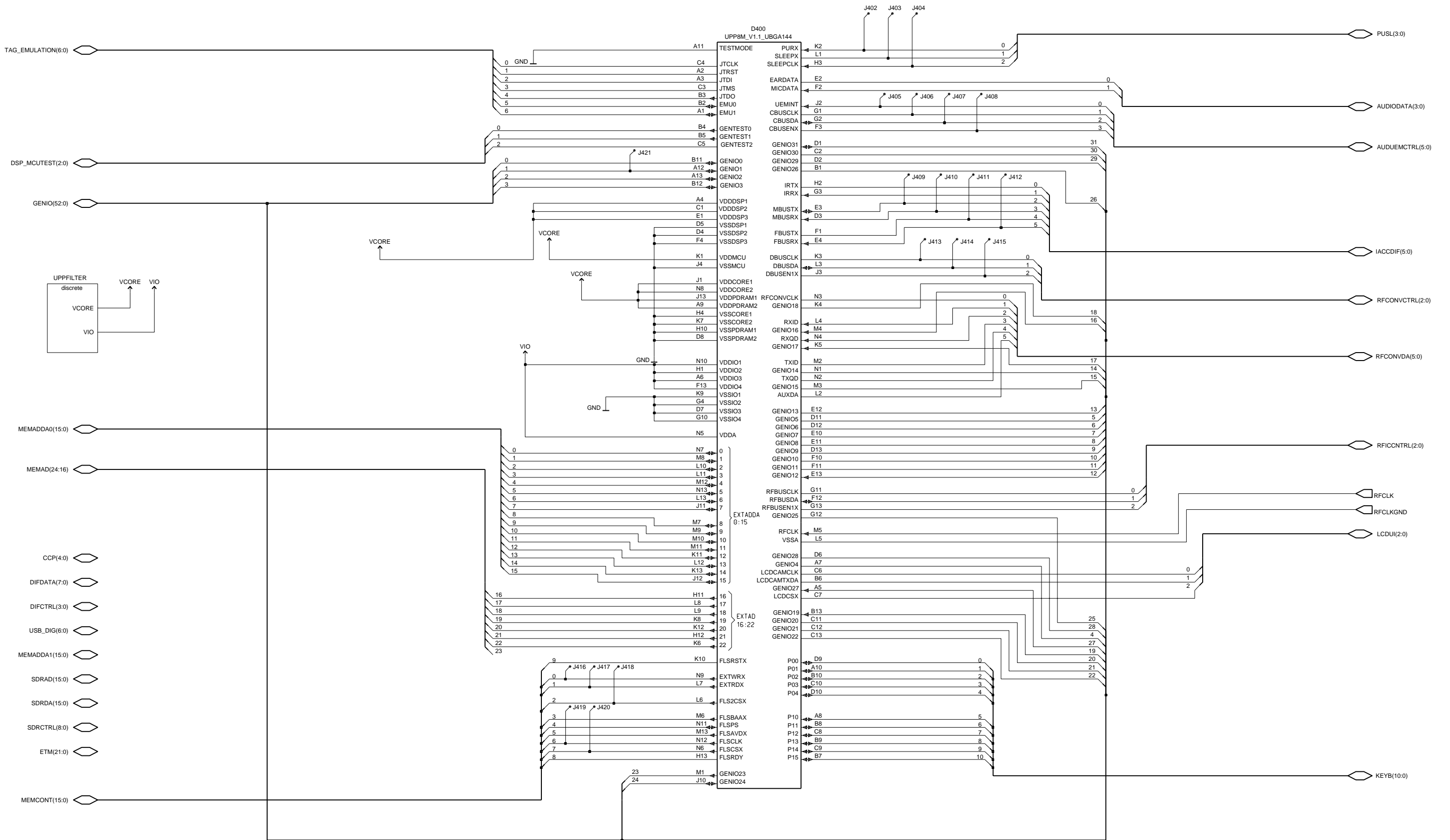

### UPP Filter

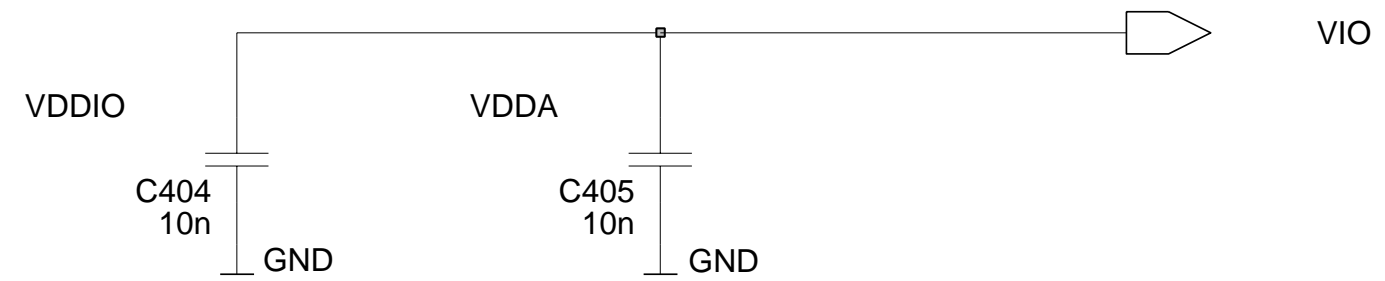
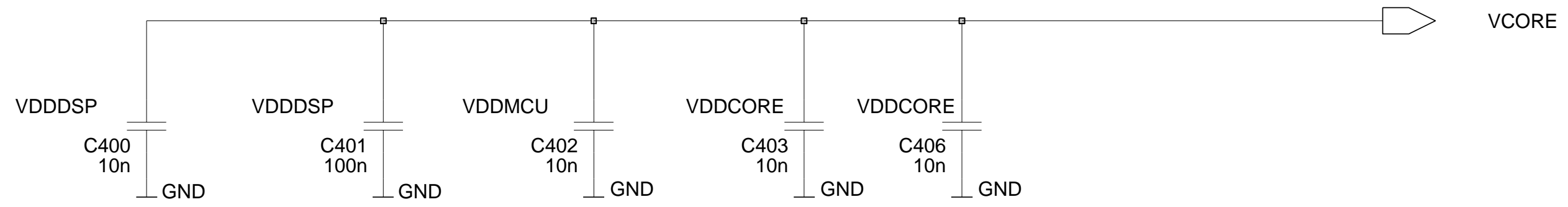



# Assembly Values Diagram Bottom

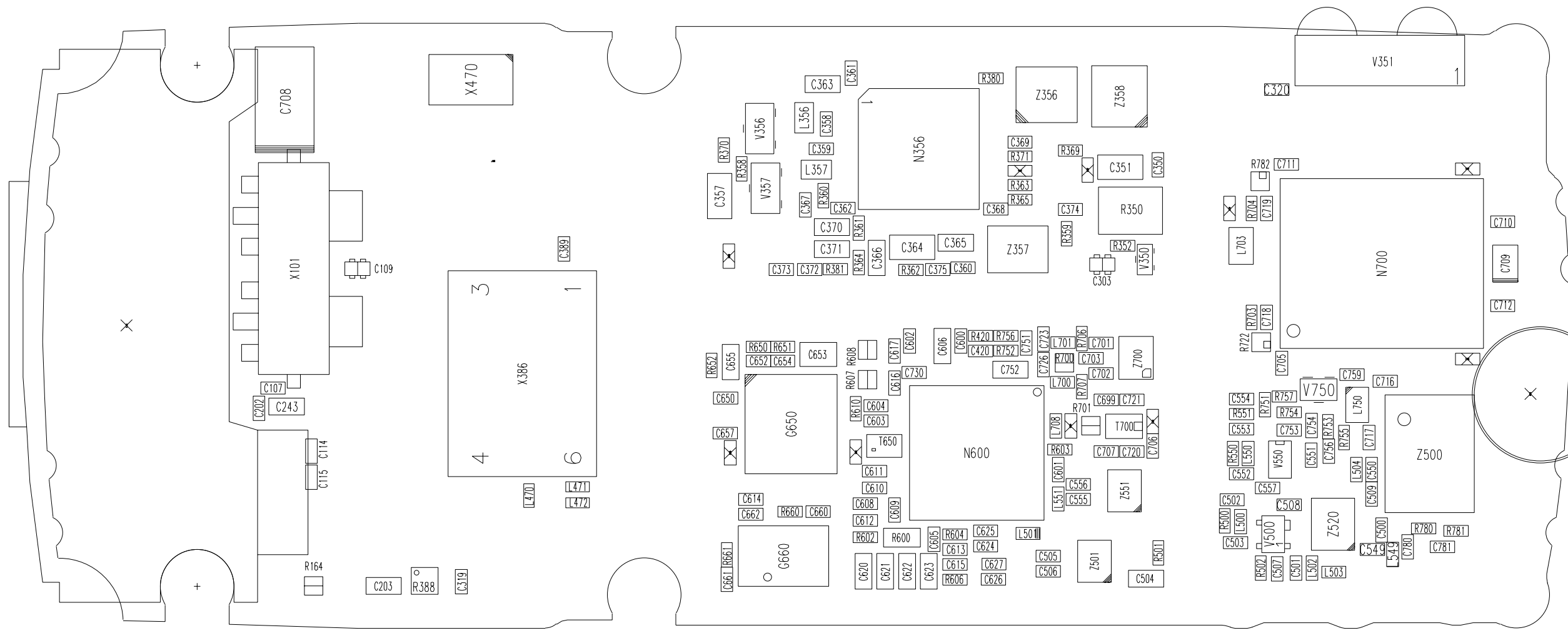

x not assembled

T	S	R	Q	P	O	N	M	L	K	J	I	H	G	F	E	D	C	B	A
---	---	---	---	---	---	---	---	---	---	---	---	---	---	---	---	---	---	---	---

9
8
7
6
5
4
3
2
1

# Assembly Values Diagram Top

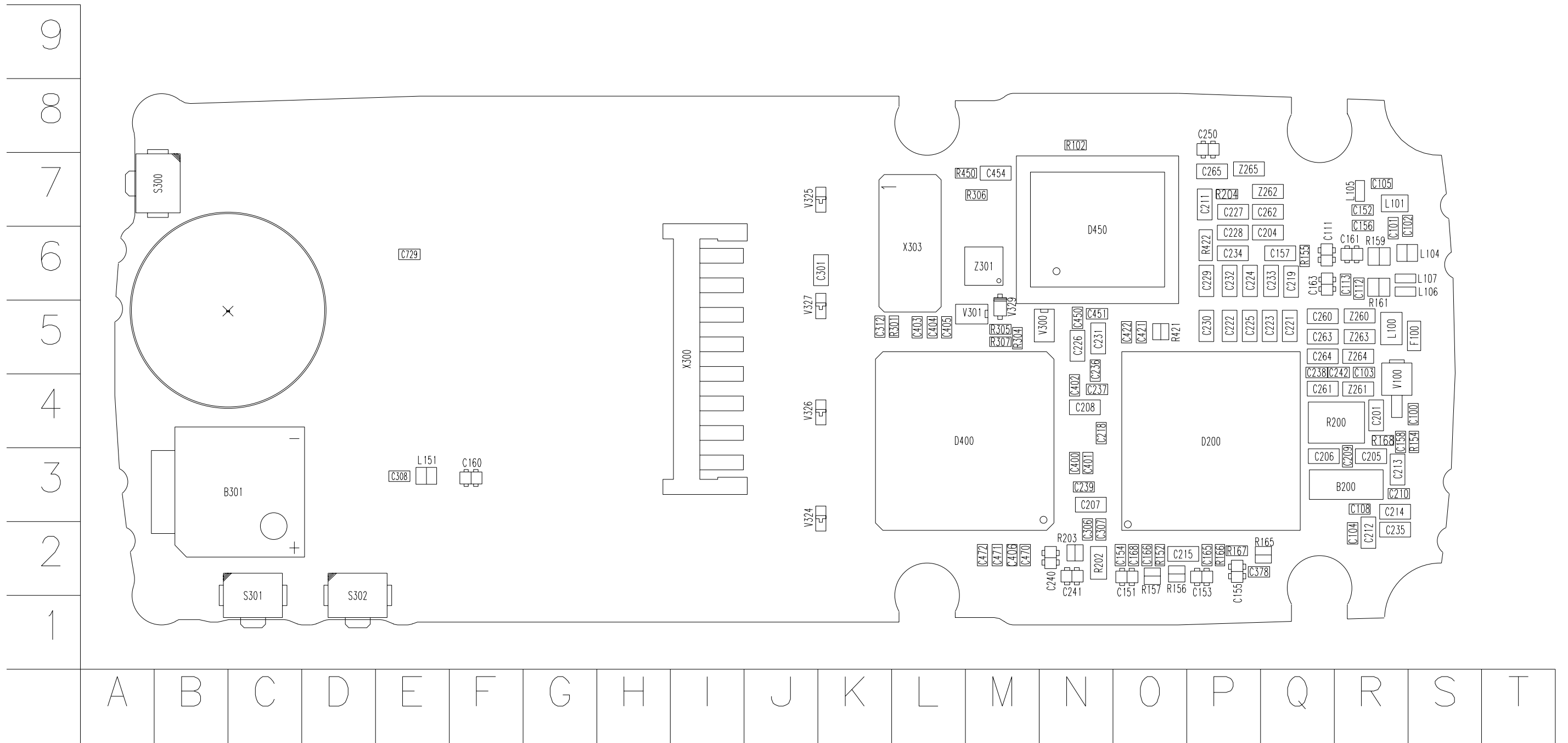

# Top Test Points

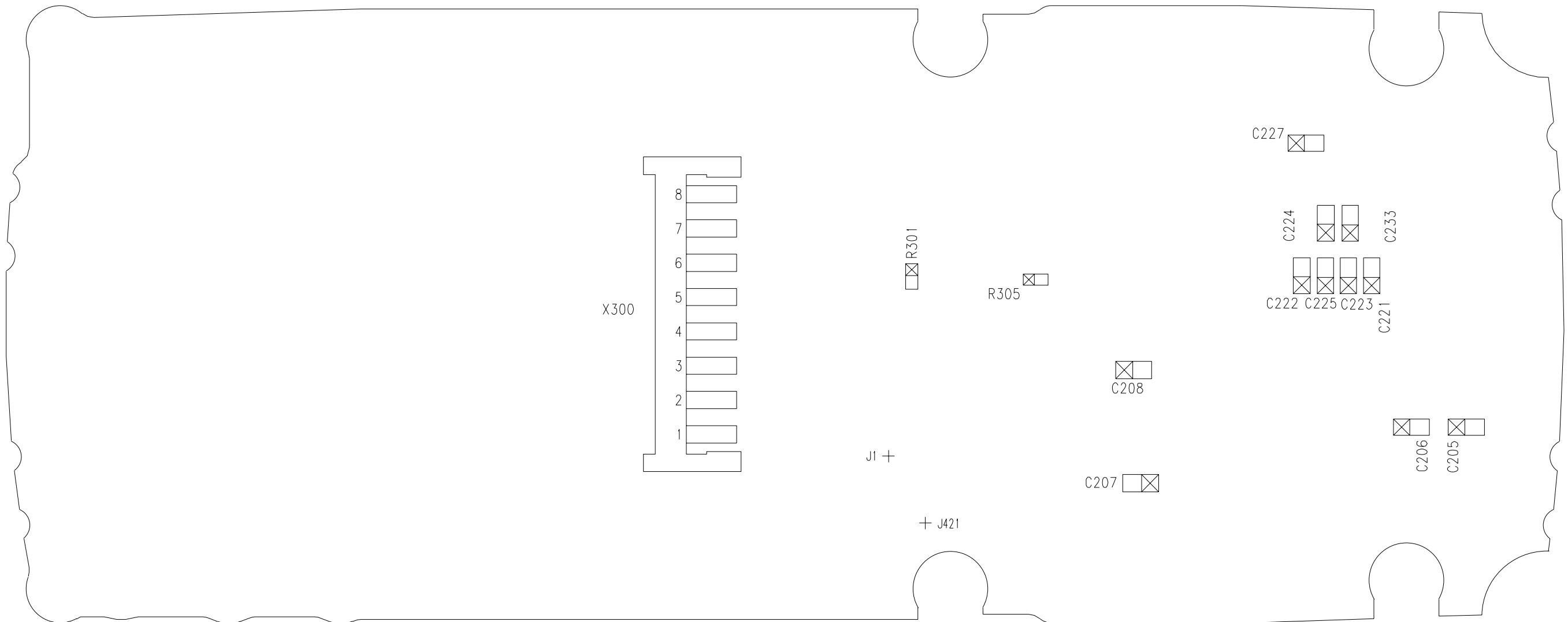

### Bottom Test Points

